



EZ-DUZ-IT



PACKAGING SOLUTIONS THAT MEAN BUSINESS

ARPAC *STRETCH*™

EZ-DUZ-IT®

LIGHT DUTY PLATFORM STRETCH WRAPPER



EZ-DUZ-IT®

The EZ-DUZ-IT® is part of a robust line of stretch wrapping equipment designed to maximize stretch film usage while ensuring the very best load unitization. All ARPACSTRETCH™ equipment is constructed with heavy-duty reinforced structural steel, and finished with non-corrosive Steel-It paint, to guarantee years of reliable wrapping. The EZ-DUZ-IT® is manufactured in the USA and sold through our nationwide distributor network.



EZ-DUZ-IT® High Profile (HP)

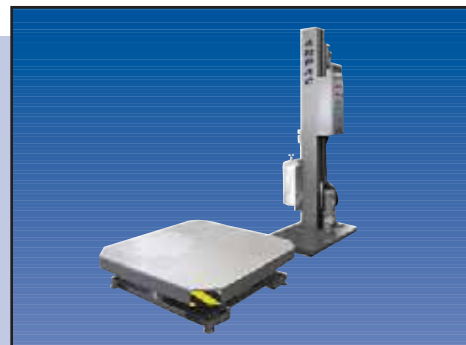

EZ-DUZ-IT® High Profile (HP) Split Frame WRAP-N-WEIGH®

The EZ-DUZ-IT® is an ideal economical wrapper for those currently hand wrapping and struggling with consistent and reliable load unitization. In addition, this system eliminates potential workplace injuries that are always present when hand wrapping.

This 4,000 lb. capacity system is available with a high profile turntable for forklift loading, and low profile turntable for pallet-jack loading. The EZ-DUZ-IT® minimizes physical bending, decreasing the risk of back injury. The standard EZ-DUZ-IT® comes completely assembled and ready to plug in.

The EZ-DUZ-IT® is often purchased with the WRAP-N-WEIGH® feature that combines wrapping and weighing into one operation by integrating a precision scale and digital controls on high or low profile turntables. Combining the two functions into one brings greater economy and efficiency to any wrapping operation requiring weighing.

The EZ-DUZ-IT® can be customized to suit your material handling requirements with extended towers for taller loads, extended bases for larger loads, and split frames for odd-sized larger loads.

TURNTABLE OPTIONS

Variety of turntable sizes are available for applications where the full skid or slip sheet needs support.

	Standard Turntable	Oversized
HP	50"W x 50"L square	60"W x 60"L square
LP	60" diameter	72" diameter

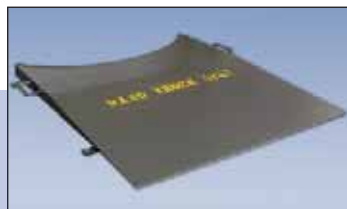

Variety of Access Ramps



Mandrel with Ergonomic Handle Design
Retains the Tension After the Film Roll is Replaced



WRAP-N-WEIGH® Operator Controls

FEATURES

- Welded heavy-duty reinforced structural steel construction for around-the-clock operation
- Steel-It paint provides a durable scratch resistant surface and prevents corrosion
- Forklift portable
- 4 point caster support for HP turntable
- 6 pairs - Delrin caster support for LP turntable
- Turntable direct drive: 1/2 HP, 90 VDC motor with ANSI 50 chain
- UL approved components
- External fuses
- Fixed turntable speed: 12 RPM
- Variable carriage speed (0-21 FPM)
- Carriage drive: 1/3 HP, 90 VDC motor with ANSI chain lift drive
- Infinite wrap pattern freedom
- Variable stretch control (manual, 0-100%)

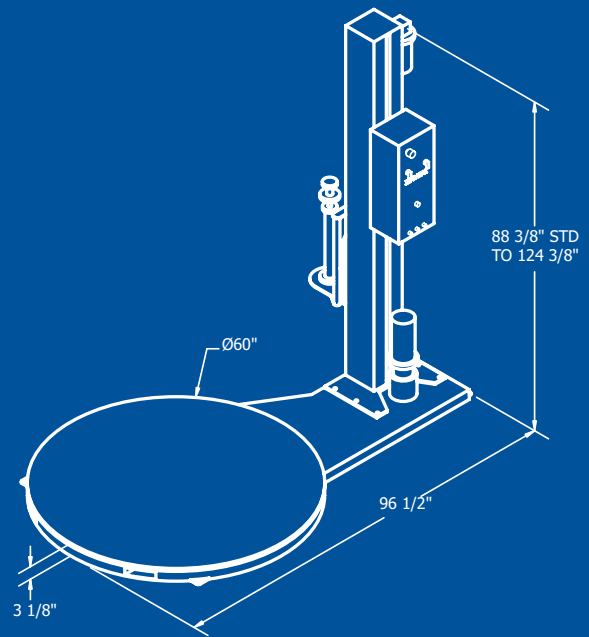
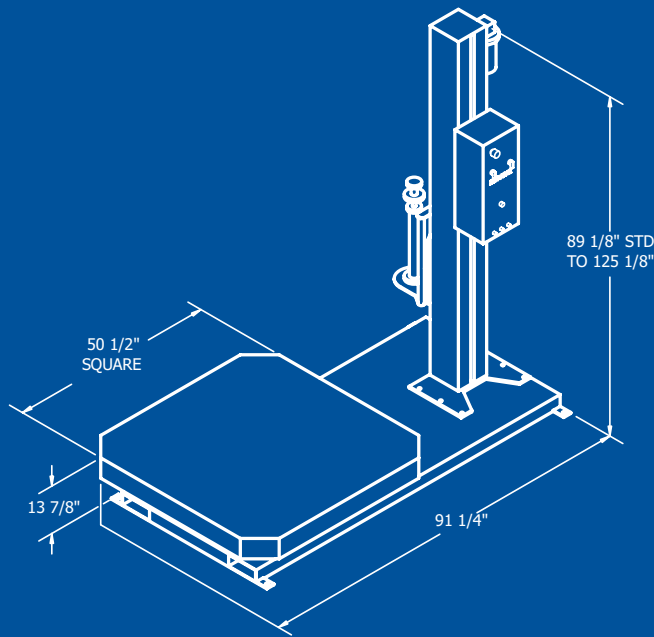

SPECIFICATIONS

Power Requirements

- Electrical: 120V, 1Ph, 60Hz, 10A

Load Sizes

Frame	Load Height	Max. Load Diagonal Clearance
HP	74"	85"
LP	84"	85"
HP WNW	72"	85"
LP WNW	81"	85"

Note: A split frame design will lose up to 3" in wrap height with a standard 8' umbilical cord between the tower and the base when turntable is placed at maximum distance from the tower.

Approx. Shipping Weight

- HP: 1,045 lbs.
- LP: 1,114 lbs.

OPTIONS

- Extended base frames offer additional turning clearance for oversized pallets
- Extended film tower for wrapping taller loads exceeding standard machine capability
- A variety of access ramps to assist loading of pallet
- WRAP-N-WEIGH® configuration combines wrapping and weighing into one operation
- Split frame construction to increase film tower clearance for oversized loads
- Extended umbilical cords for split frame models
- More options available, consult your local ARPACSTRETCH™ representative

For complete product line, visit: www.arpac.com

