

PAC-SERIES



PACKAGING SOLUTIONS THAT MEAN BUSINESS

ARPAC *STRETCH* TM

PAC-SERIES

PLATFORM AUTOMATIC CONVEYORIZED STRETCH WRAPPER

PAC-SERIES



The PAC-SERIES is part of a robust line of stretch wrapping equipment designed to maximize stretch film usage while ensuring the very best load unitization. All ARPACSTRETCH™ equipment is constructed with heavy-duty reinforced structural steel and finished with non-corrosive Steel-It paint, to guarantee years of reliable wrapping. The PAC-SERIES is manufactured in the USA and sold through our nationwide distributor network.

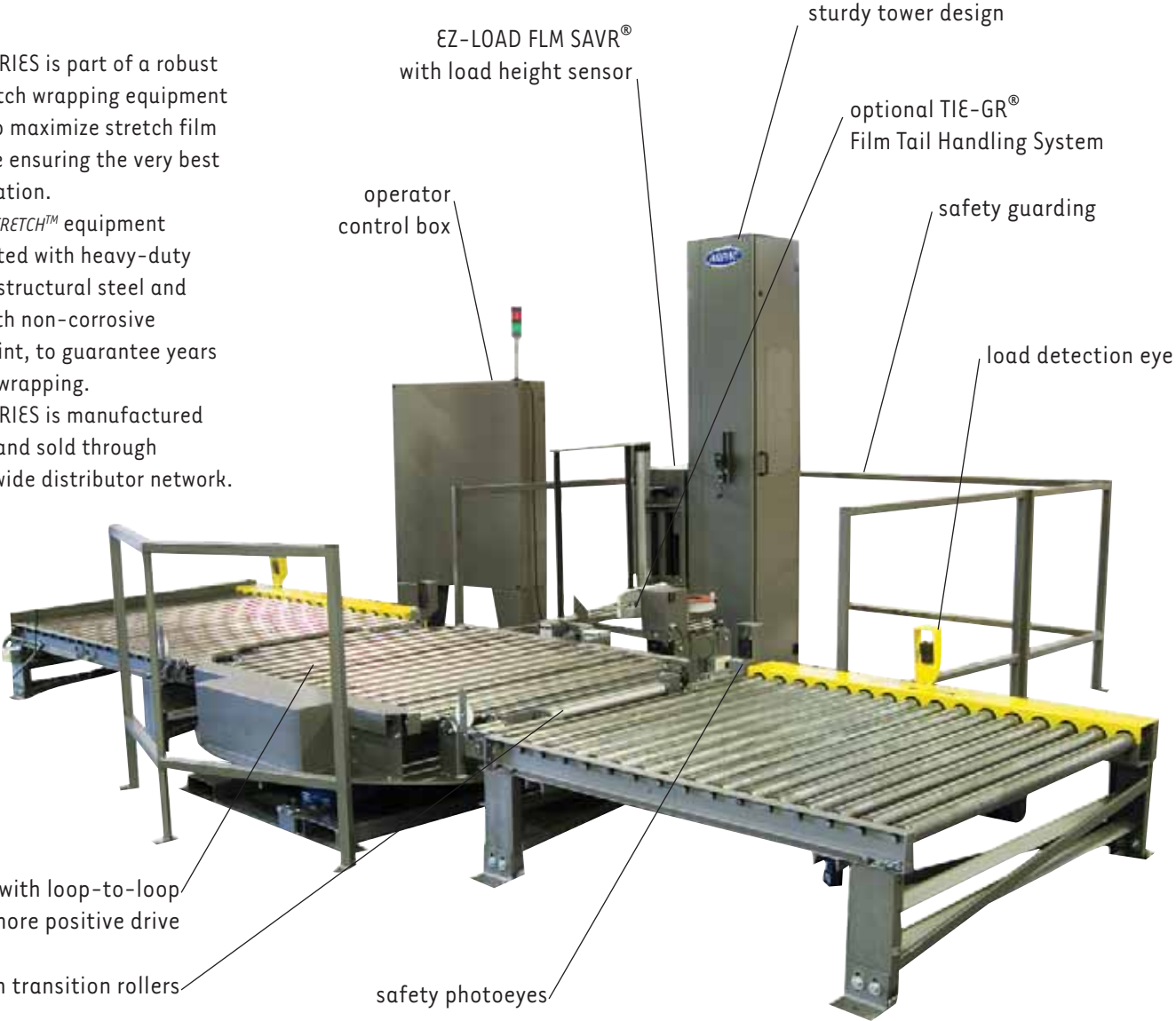

PAC 4R5 model shown



Film Clamp/Cut/Wipe Assembly Cuts and Attaches the Film Tail to the Pallet Load



User-Friendly Operator Controls



Top Sheet Dispenser for Additional Product Protection

The PAC-SERIES heavy-duty conveyORIZED automatic turntable stretch wrapping system provides superior performance around-the-clock. Ideal for high speed conveyORIZED production lines, this inline system indexes pallet loads, automatically into and out of the wrap zone and discharges loads without operator assistance.

At the end of the wrap cycle, the wipe arm aligns the film with the clamp arm. Once the clamp arm captures the film, the hot wire cuts the film and the wipe arm makes a secondary motion wiping the film onto the load to prevent film tails from unraveling.

Rugged power roller conveyors are used for passing loads through the PAC-SERIES wrap zone. These conveyors are driven by ANSI chains with sprocket guarding, and are guarded with heavy gauge formed sheet metal.

The PAC-SERIES can be manufactured with several performance enhancements. The optional TIE-GR® Film Tail Handling System eliminates film tails by securing the tail to the pallet. The TOP PLATEN device is used to hold down unstable pallet loads during the wrapping sequence, and a Top Sheet Dispenser covers the top of the pallet with film, for additional product protection from moisture.

MODELS

	Conv. speed	T/T speed	Min. load size	Max. load size	Max. load weight
PAC-4R2	30 FPM	12 RPM	36"W x 36"L x 24"H	48"W x 48"L x 65"H	4,000 lbs.
PAC-4R5	30 FPM	15 RPM	30"W x 30"L x 24"H	above 18" conv.	4,000 lbs.

Other sizes available. Consult factory for more information

OPTIONAL TIE-GR® FILM TAIL HANDLING SYSTEM WITH ROPING DEVICE

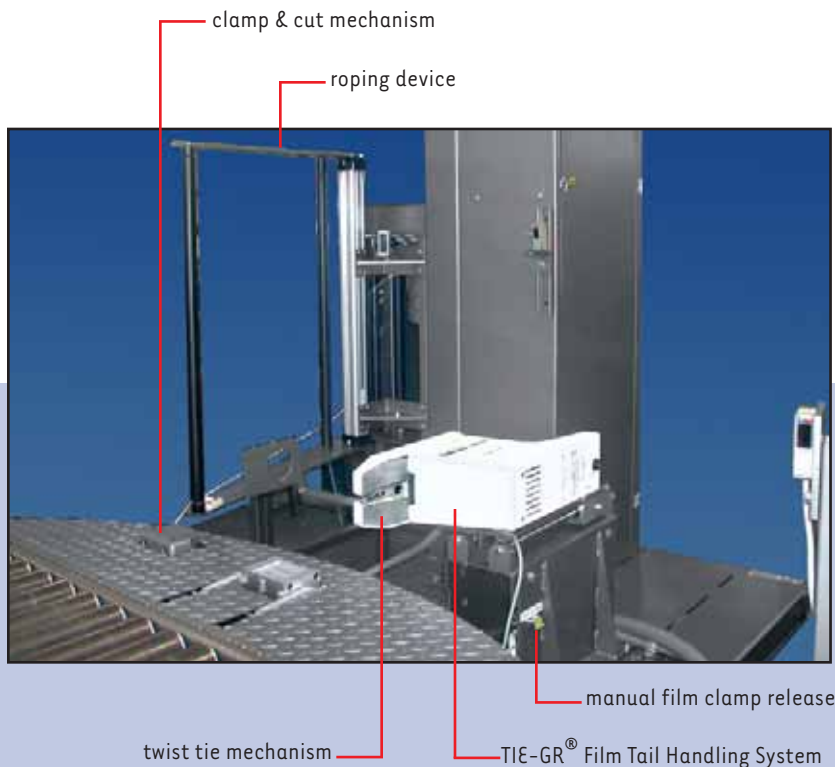

FEATURES

- Heavy-duty reinforced structural steel construction for around-the-clock operation
- Steel-It paint provides a durable scratch resistant surface and prevents corrosion
- Allen-Bradley® Micrologix PLC
- User-friendly operator controls with dual LED counters
- Built in self-diagnostics
- Electronically controlled film tension adjustment
- Top over-wrap control
- Adjustable top and bottom wrap counters (0-9)
- Turntable drive: 3/4 HP DC motor with ANSI 60 chain
- Turntable conveyor: 52"W x 2.5" diameter rolls, 11 gauge steel with 11/16" hex shafts
- Manual conveyor controls
- Mechanical lock holds turntable in position during load, infeed and exits
- 42" safety fencing with intralocking access doors
- Automatic film clamp and cut device with manual override control
- Film fault alarm that signals empty film roll, film brakes, or that equipment needs attention
- Photo electronic load height sensor that detects most dark colored loads
- Variable carriage speed (0-21FPM)
- EZ-LOAD FILM SAVR® Powered Pre-Stretch: up to 300% with minimum neck down
- Film delivery system: 1/2 HP, 90 VDC motor
- Dual chain carriage lift system
- Anti-static rollers
- Corner compensation
- UL approved components
- External fuses
- Dust tight NEMA 12 enclosure

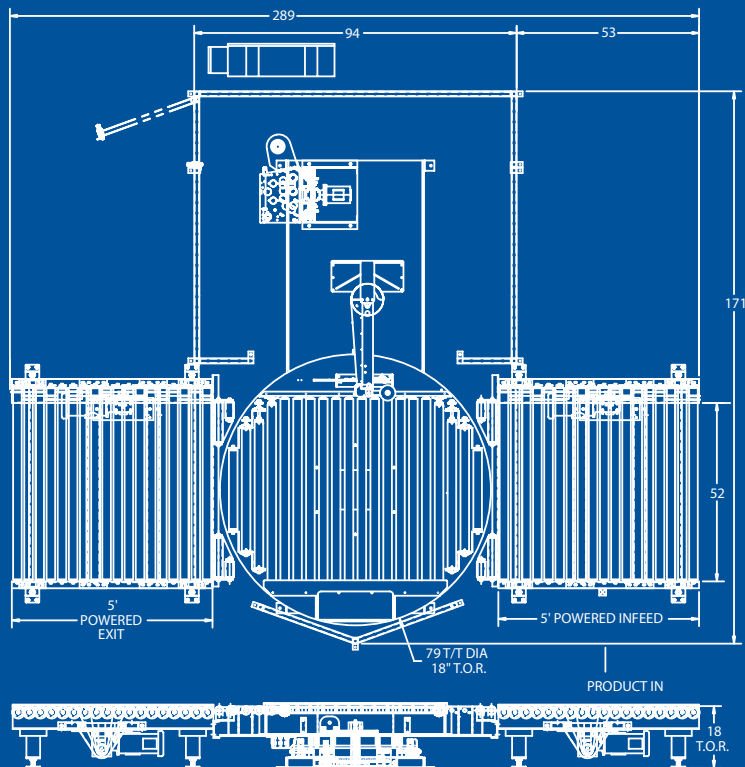

SPECIFICATIONS

Power Requirements

- Electrical: 220V, 3Ph, 60Hz, 20A
- Pneumatics: 80 psi, 3 SCFM

Approx. Shipping Weight

- 4,950 lbs. w/conveyors

OPTIONS

- TIE-GR® Film Tail Handling System secures film tail to load
- Roping option with special roping sequences available
- 30" film capacity available
- Various flow configurations available
- Exit conveyor interlock
- Variable speed conveyors
- 6' safety fencing
- Fork truck safety eye prevents conveyor section from running while loading or unloading
- WRAP-N-WEIGH® feature can be integrated into conveyor
- Various turntable heights, tower extensions and conveyor lengths to suit your application and production environment
- Air operated turntable transfer unit
- TOP PLATEN device used to stabilize tall or light unstable loads during rotation
- Top Sheet Dispenser options for dust cover or weather proofing

