



PA-SERIES PLUS



PACKAGING SOLUTIONS THAT MEAN BUSINESS

ARPAC *STRETCH*™

PA-SERIES PLUS

2-STATION PLATFORM AUTOMATIC STRETCH WRAPPER

PA-SERIES PLUS



The PA-SERIES PLUS is part of a robust line of stretch wrapping equipment designed to maximize stretch film usage while ensuring the very best load unitization. All ARPAC *STRETCH™* equipment is constructed with heavy-duty reinforced structural steel and finished with Steel-It paint to guarantee years of reliable wrapping. The PA-SERIES PLUS is manufactured in the USA and sold through our nationwide distributor network.

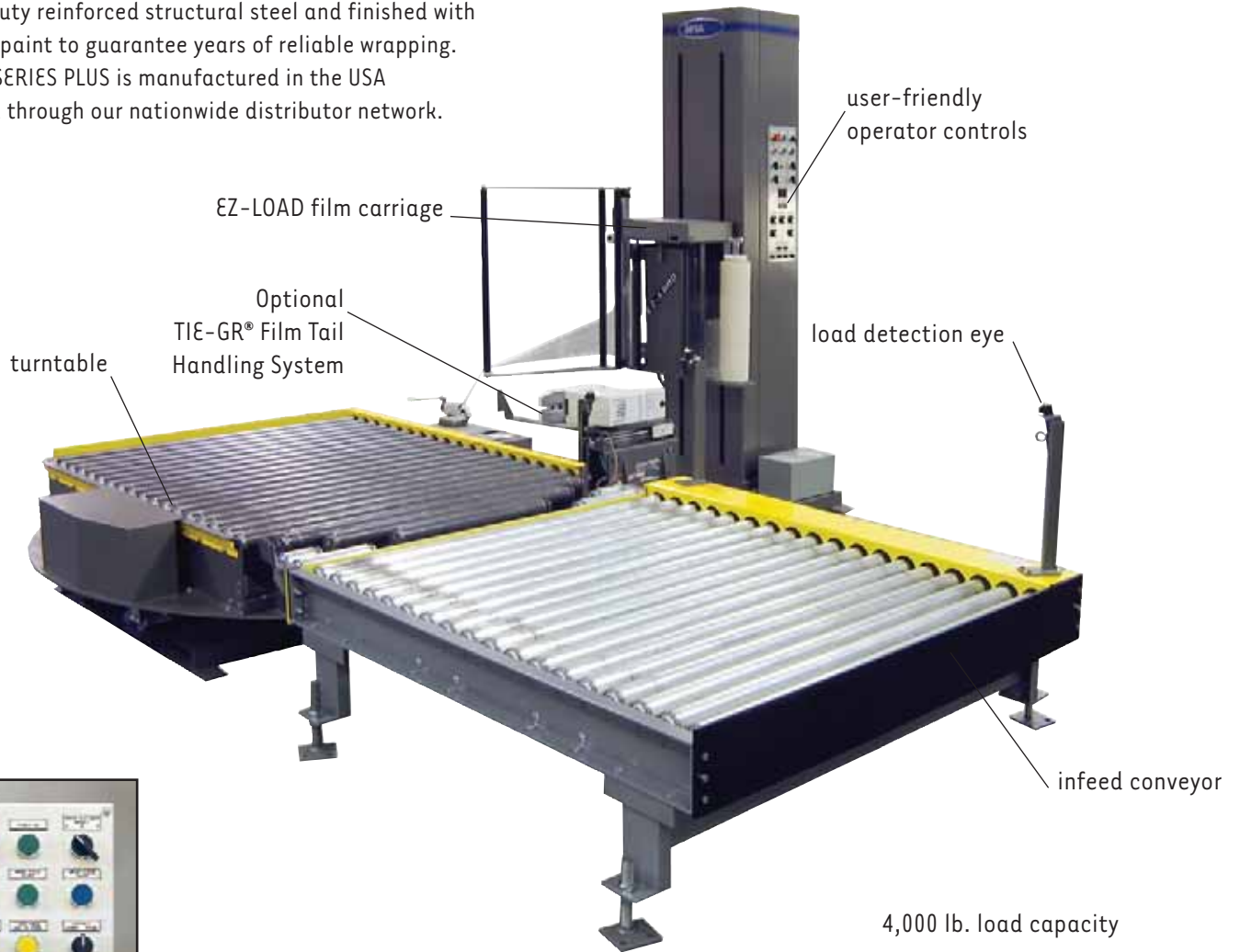

User-Friendly Operator Controls



Remote Pendant with Emergency Stop, Cycle Start and Stop



Direct Drive System

The PA-SERIES PLUS is a 2-station system that increases forklift operator productivity. This turntable stretch wrapper is completely accessible to forklift operators without getting off the truck, thereby reducing the operators need to handle a load more than once.

The forklift places the pallet onto the powered infeed conveyor and activates the system from a remote pendant with an emergency stop feature. On activation, the pallet is transferred from the infeed conveyor and is automatically situated onto the turntable conveyor for the wrapping sequence. A new load may be placed on the infeed conveyor once the load has indexed onto the turntable conveyor.

When the wrapping cycle is complete, the TIE-GR® Film Tail Handling System automatically clamps, cuts, ties and secures the film to the pallet, leaving no film tail to worry about.

OPTIONAL TIE-GR® FILM TAIL HANDLING SYSTEM & ROPING DEVICE

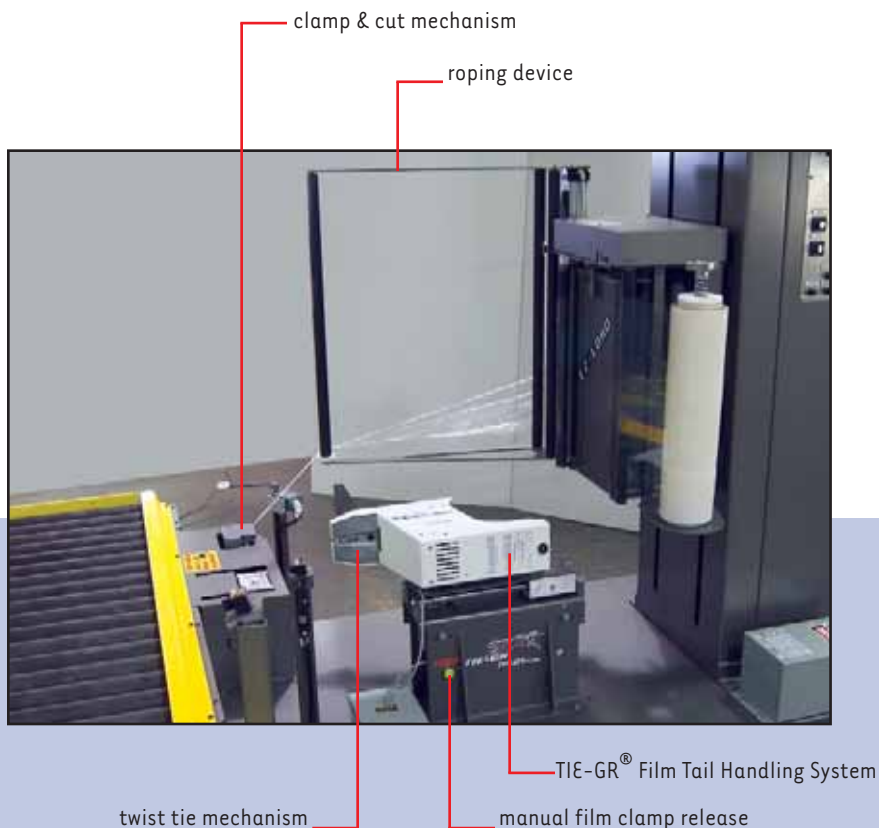

FEATURES

- Heavy-duty reinforced structural steel construction for around-the-clock operation
- Steel-It paint provides a durable scratch resistant surface and prevents corrosion
- 4 point caster support
- Turntable direct drive: 3/4 HP, DC motor with ANSI 60 chain direct drive
- Powered infeed conveyor
- Allen-Bradley® Micrologix PLC
- User-friendly operator controls with dual LED wrap counters
- Built in self-diagnostics
- Electronically controlled film tension adjustment
- 3 wrap pattern selections
- Remote pendant with emergency stop, cycle start and cycle stop
- Top over-wrap control feature
- Cycle pause control
- Carriage pause control (banding)
- Positive home position alignment
- Photo electric load height sensor that detects most dark colored loads
- Adjustable top and bottom wrap counters (0-9)
- UL approved components
- External fuses
- Corner compensation
- Anti static rollers
- Variable turntable speed (0-12 RPM)
- Variable carriage speed, (0-21 FPM)
- EZ-LOAD FILM SAVR® Powered Pre-Stretch up to 300%
- Film delivery: 1/2 HP, 90 VDC motor

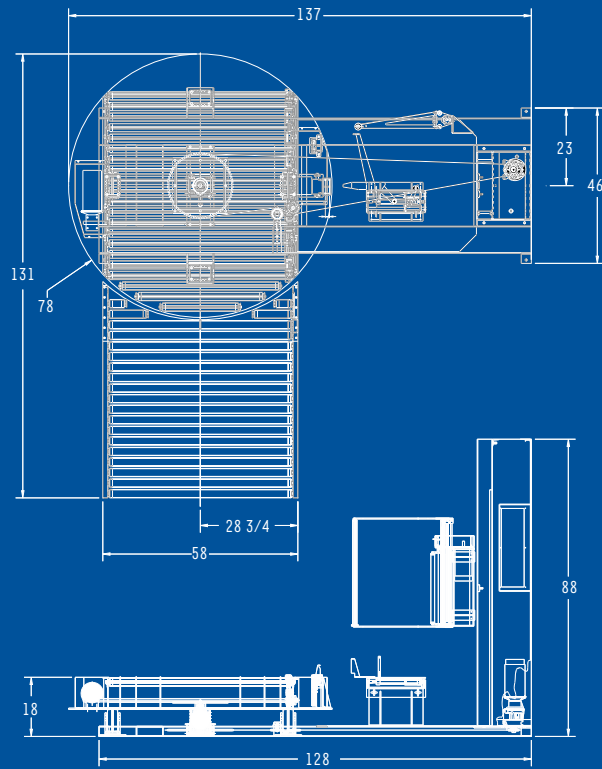

SPECIFICATIONS

Power Requirements

- Electrical: 480/242V, 1Ph, 60Hz, 10A
- Pneumatic: 80 psi, 3 SCFM

Load Size

- Min.: 30"W x 30"L x 24"H
- Max.: 50"W x 50"L x 65"H

Approx. Shipping Weight

- HP: 4,125 lbs.

OPTIONS

- Tower extensions for larger loads
- Portable air compressor
- WRAP-N-WEIGH® feature combines wrapping and weighing in one operation
- Special roping sequences available
- TOP PLATEN device used to stabilize tall or light unstable loads during rotation
- TIE-GR® Film Tail Handling System with roping device

For complete product line, visit: www.arpac.com

