

# Automatic Round Product Labeling

*Bringing speed and affordability together.*

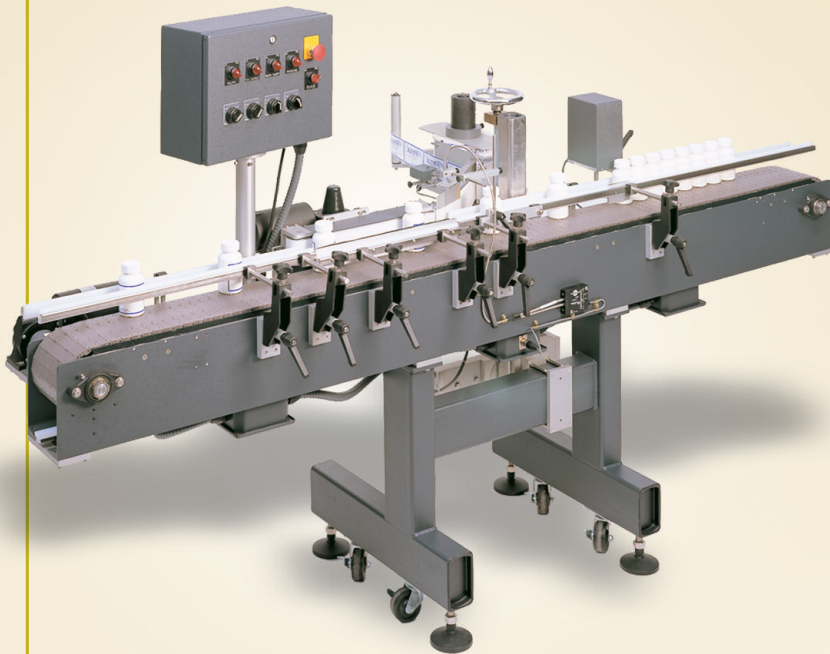

## R320

Automatic Round Product Labeling System delivers speed and efficiency in one affordable system. The R320 features:

- Heavy-duty steel framework with casters and leveling pads.
- L15H label applicator
- Variable speed components.
- Photoelectric product sensor.
- Easy access control enclosure.

## R322

High Speed Automatic Round Product Labeling System delivers high speed and efficiency in one affordable system. The R322 features:

- Heavy-duty steel framework with casters and leveling pads.
- SL2000 stepper driven label applicator
- Variable speed components.
- Photoelectric product sensor.
- Easy access control enclosure.

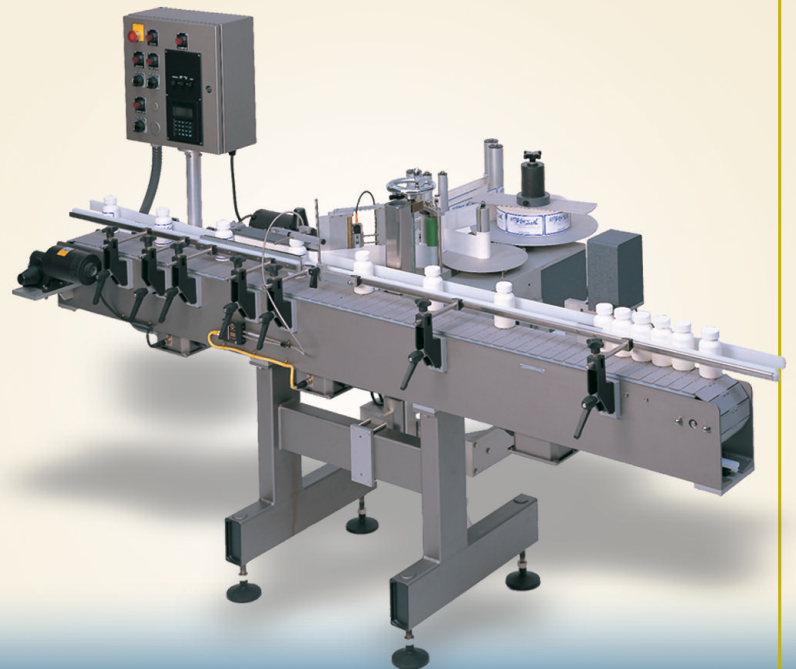

**UNIVERSAL**  
*labeling systems*

Engineering  
labeling solutions.

# SPECIFICATIONS

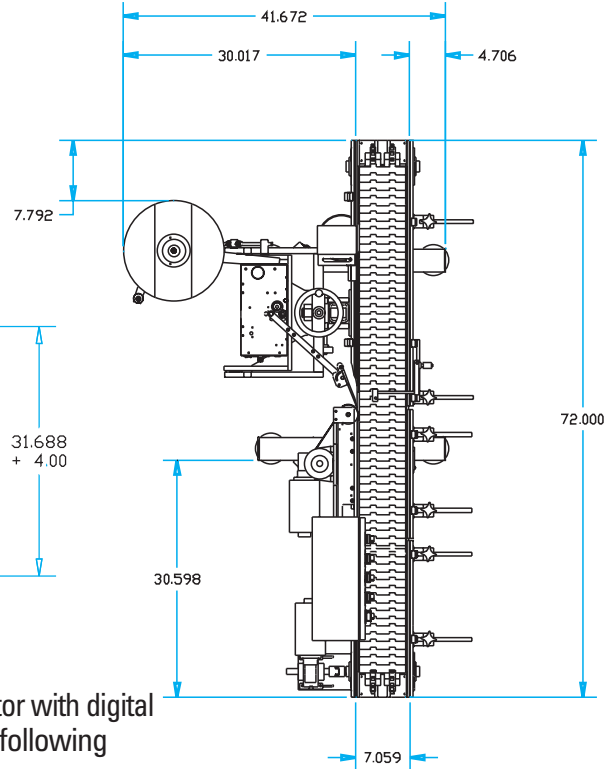
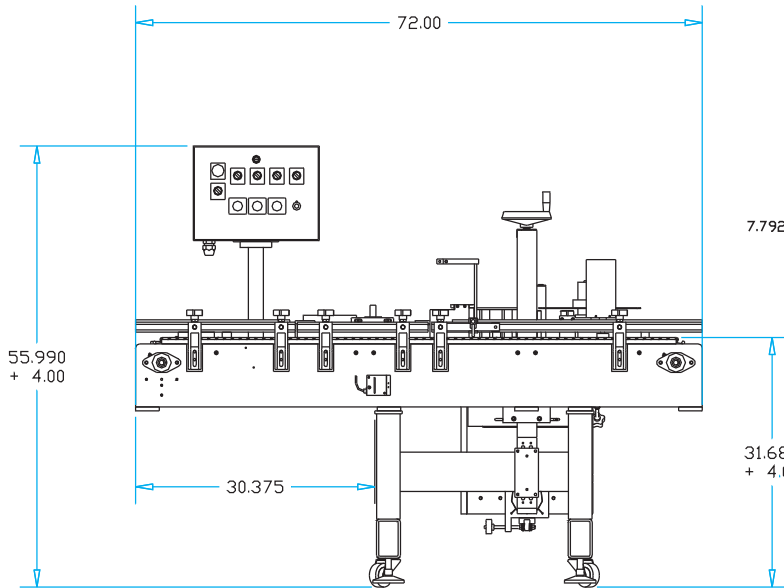

## R320

- 42" W x 72" L x 56" H
- Speed: up to 1200" per min.
- Label roll capacity: 12" Ø
- Web width: up to 6.375"
- Electric: 120 VAC +/-10%
- Shipping weight: approx. 1075 lbs.

### Options

- SL1000 label applicator with digital controls and speed following
- Hot stamp imprinter
- Feed and accumulating tables
- Wide label kit

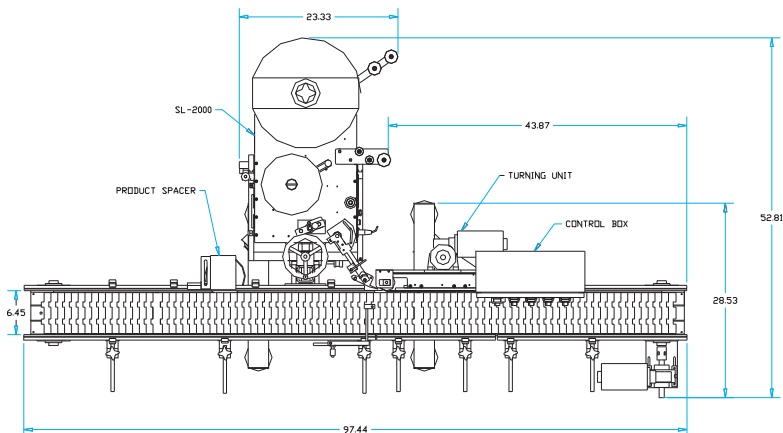
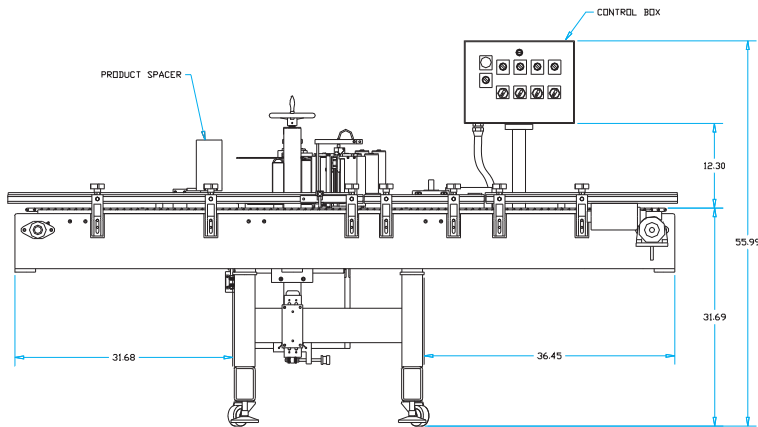

## R322

- 53" W x 97" L x 56" H
- Speed: up to 3000" per min.
- Label roll capacity: 16" Ø
- Web width: up to 6.375"
- Electric: 120 VAC +/-10%
- Shipping weight: approx. 1160 lbs.

### Options

- Hot stamp imprinter
- Feed and accumulating tables
- Wide label kit
- Feed screw or belt metering

### Universal Labeling Systems, Inc.

3501 8th Avenue South • St. Petersburg, FL 33711

1-877-236-0266 • sales@universal1.com

www.universal1.com